

CLARKE[®] **METALWORKER**



**BENCH GRINDER WITH LIGHT AND
WIRE WHEEL**

MODEL NO: CBG8370LW

PART NO: 6500533

**OPERATION & MAINTENANCE
INSTRUCTIONS**



ORIGINAL INSTRUCTIONS

GC0820 - REV 7

INTRODUCTION

Thank you for purchasing this CLARKE Bench Grinder with light and wire wheel. Before attempting to use this product, please read this manual thoroughly and follow the instructions carefully. In doing so you will ensure the safety of yourself and that of others around you, and you can look forward to your purchase giving you long and satisfactory service.

GUARANTEE

This product is guaranteed against faulty manufacture for a period of 12 months from the date of purchase. Please keep your receipt which will be required as proof of purchase.

This guarantee is invalid if the product is found to have been abused or tampered with in any way, or not used for the purpose for which it was intended.

Faulty goods should be returned to their place of purchase, no product can be returned to us without prior permission. This guarantee does not effect your statutory rights.

SPECIFICATIONS

Model Number	CBG8370LW
Rated Voltage	230V~50Hz
Rated Input	250 W (S1)
No Load Speed	2980 RPM
Sound Pressure Level LpA	84 db
Sound Power Level LWA	94 db
Uncertainty Factor K	3
Weight	14.85 kg
Abrasive wheels supplied	Coarse (36 Grit), Wire Wheel
Grinding Wheel dimensions	Dia (200mm) Thickness (20mm) Bore (15.88 mm)
Wire Wheel dimensions	Dia (200mm) Thickness (16mm) Bore (15.88 mm)

POWER TOOL SAFETY WARNINGS

WORK AREA

1. **Keep the work area clean and well lit.** Cluttered and dark areas invite accidents.
2. **Do not operate power tools in explosive atmospheres, such as in the presence of flammable liquids, gases or dust.** Power tools create sparks which may ignite the dust or fumes.
3. **Keep children and bystanders away while operating a power tool.** Distractions can cause you to lose control.

ELECTRICAL SAFETY

1. **Power tool plugs must match the outlet. Never modify the plug in any way. Do not use adaptor plugs with earthed (grounded) power tools.** Unmodified plugs and matching outlets will reduce the risk of electric shock.
2. **Do not expose power tools to rain or wet conditions.** Water entering a power tool will increase the risk of electric shock.
3. **Do not abuse the cable. Never use it for carrying, pulling or unplugging the power tool. Keep the cable away from heat, oil, sharp edges or moving parts.** Damaged or entangled cables increase the risk of electric shock.
4. **When operating a power tool outdoors, use an extension cable suitable for outdoor use.** Use of a cable suitable for outdoor use reduces the risk of electric shock.
5. **If operating the power tool in a damp location is unavoidable, use a residual current device (RCD) protected supply.**

PERSONAL SAFETY

1. **Stay alert, watch what you are doing and use common sense when operating a power tool.** Do not use a power tool while you are tired or under the influence of drugs, alcohol or medication. A moment of inattention while operating power tools may result in personal injury.
2. **Use safety equipment. Always wear eye protection.** Safety equipment such as dust mask, non-skid safety shoes, hard hat, or hearing protection used for appropriate conditions will reduce personal injuries.
3. **Avoid accidental starting.** Ensure the switch is in the off position before plugging in. Carrying power tools with your finger on the switch or plugging in power tools that have the switch on invites accidents.
4. **Remove any wrench before turning the power tool on.** A wrench left attached to a rotating part may result in personal injury.
5. **Do not overreach.** Keep proper footing and balance at all times. This enables better control of the power tool in unexpected situations.
6. **Dress properly.** Do not wear loose clothing or jewellery. Keep your hair, clothing and gloves away from moving parts. Loose clothes, jewellery or long hair can be caught in moving parts.

POWER TOOL USE AND CARE

1. **Do not force the power tool.** Use the correct accessories for your application. The correct power tool will do the job better and safer at the rate which it was designed.
2. **Do not use the power tool if the switch does not turn it on and off.** Any power tool that cannot be controlled with the switch is dangerous and must be repaired.
3. **Disconnect the plug from the power source before changing accessories, or storing power tools.** Such preventive safety measures reduce the risk of starting the power tool accidentally.
4. **Store idle tools out of the reach of children and do not allow persons unfamiliar with the power tool or these instructions to operate it.** Power tools are dangerous in the hands of untrained users.
5. **Maintain power tools.** Check for misalignment or binding of moving parts, breakage of parts and any other condition that may affect the power tool's operation. If damaged, have the power tool repaired before use. Many accidents are caused by poorly maintained power tools.
6. **Use the power tool and accessories in accordance with these instructions and in the manner intended, taking into account the working conditions and the work to be performed.** Use of the power tool for operations different from intended could result in a hazardous situation.
7. The performance of this tool may vary, depending upon variations in line voltage. Extension cable usage may also affect performance.

SERVICING

1. **Have your power tool serviced by qualified service personnel using only identical replacement parts.** This will ensure that the safety of the power tool is maintained.

BENCH GRINDER SAFETY WARNINGS

1. Hold the hand tool or blade being sharpened firmly to prevent loss of control.
2. NEVER install an abrasive flap wheel or sanding disc on this grinder.
3. Always replace a cracked grinding wheel immediately.
4. Never use damaged or incorrect grindstones. The stone and retaining bolt were specially designed for your grinder, for optimum performance and safety of operation. Inspect the condition of the grinding stone before use and do not use if any damage is noticed.
5. Do not use aluminium oxide wheels when grinding non-ferrous metals such as aluminium or brass. Use silicon carbide wheels (not included) for grinding non-ferrous metals.

6. Always use the tool rests to steady the workpiece. If the tool attachments are not used, the torque of the spinning grinding/polishing wheel may pull the workpiece from your hands.
7. Never leave the grinder unattended when it is connected to an electrical power supply. Switch off the machine and unplug it before leaving.
8. ALWAYS check for damaged parts. Before further use of the tool, a guard or other part that is damaged should be carefully checked to determine if it would operate properly and perform its intended function. Check for misalignment or binding of moving parts, breakage of parts and any other condition that may affect the tool's operation. A part that is damaged should be properly repaired or replaced at an authorised service centre. Following this rule will reduce the risk of electric shock, fire or serious injury.
9. Eye protection manufactured to the current European safety standards should be worn when operating grinding equipment.
10. Eye guards supplied with the machine must be used at all times.

Note: Bench grinders used in industrial environments may be subject to the requirements of The Provision and Use of Work Equipment regulations 1992 (particularly regarding the training requirement of The Abrasive Wheels Regulations 1970), or other legislation. If in doubt seek advice.

SAFETY SYMBOLS



Read Instruction Manual Before Use



This Machine Is Not Suitable For Hand Held Use



Not Permitted For Wet Grinding



Wear Eye Protection



Wear Ear Defenders

ELECTRICAL CONNECTIONS



WARNING: READ THESE ELECTRICAL SAFETY INSTRUCTIONS THOROUGHLY BEFORE CONNECTING THE PRODUCT TO THE MAINS SUPPLY.

Before switching the product on, make sure that the voltage of your electricity supply is the same as that indicated on the rating plate. This product is designed to operate on 230VAC 50Hz. Connecting it to any other power source may cause damage.

This product may be fitted with a non-rewireable plug. If it is necessary to change the fuse in the plug, the fuse cover must be refitted. If the fuse cover becomes lost or damaged, the plug must not be used until a suitable replacement is obtained.

If the plug has to be changed because it is not suitable for your socket, or due to damage, it should be cut off and a replacement fitted, following the wiring instructions shown below. The old plug must be disposed of safely, as insertion into a mains socket could cause an electrical hazard.



**WARNING: THE WIRES IN THE POWER CABLE OF THIS PRODUCT ARE COLOURED IN ACCORDANCE WITH THE FOLLOWING CODE:
BLUE = NEUTRAL BROWN = LIVE YELLOW AND GREEN = EARTH**

If the colours of the wires in the power cable of this product do not correspond with the markings on the terminals of your plug, proceed as follows.

- The **Blue** wire must be connected to the terminal marked **N** or coloured **Black**.
- The **Brown** wire must be connected to the terminal marked **L** or coloured **Red**.
- The **Yellow and Green** wire must be connected to the terminal marked **E** or  or coloured **Green**.

Plug must be BS1363/A approved.

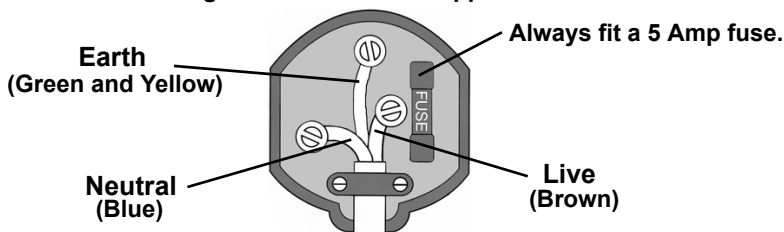

Ensure that the outer sheath of the cable is firmly held by the clamp

We strongly recommend that this machine is connected to the mains supply via a Residual Current Device (RCD)

If in any doubt, consult a qualified electrician. DO NOT attempt any repairs yourself.

CARTON CONTENTS

The following items should be supplied in the carton. If any parts are missing or damaged, please contact the Clarke dealer where you purchased the bench grinder.

1 x Bench Grinder Assy with Lamp (grinding wheel + 1 wire wheel attached)
2 x Eye Shields (1 with Built-in Magnifying Lens)
2 x Eye Shield Arms with bolts and washers
2 x Eye Shield Brackets
1 x Hand Knob with washer
1 x Spark Deflector with bolts and washers
1 x Tool Rest with screws and washers
1 x Wheel Dresser

PART IDENTIFICATION

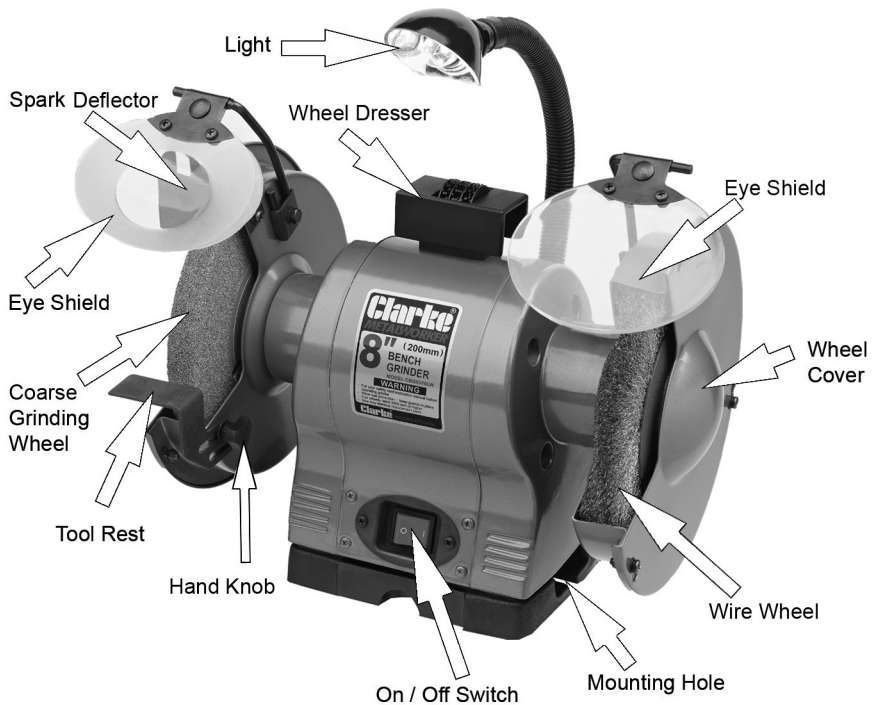

BEFORE USE

MOUNTING THE GRINDER ON A WORKBENCH

NOTE: We highly recommend that you bolt this bench grinder securely to a workbench to gain maximum stability for your machine.

1. Using the base of the bench grinder as a template, mark the bench through the holes in the casting.
2. Bolt the bench grinder to the bench with bolts, washers and nuts (not supplied).
3. To reduce vibration, mount the bench grinder on a vibration absorbing mat.

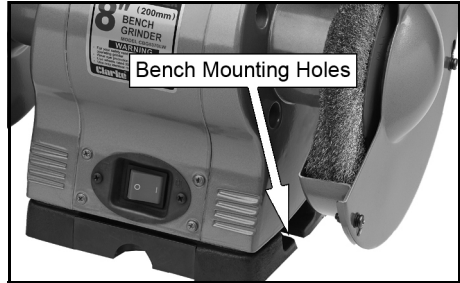

INSTALLING THE TOOL REST

1. Fix the tool rest to the bench grinder with the screw and hand knob as shown.
 - The tool rest are adjustable and should be positioned 1.5 mm from the grinding wheels.
 - Ensure that the tool rest is firmly fixed and horizontal.

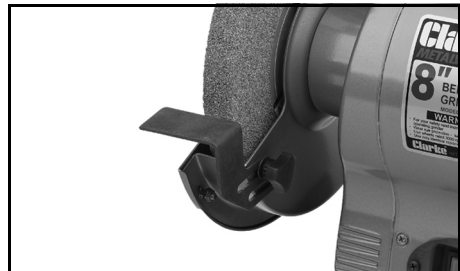

INSTALLING THE SPARK DEFLECTOR

Fit the spark deflector to the grinding wheel guard using the screws provided.

- Adjust the spark deflector frequently to compensate for wear of the wheel, keep the distance between the spark deflector and wheel as small as possible and never more than 2mm.

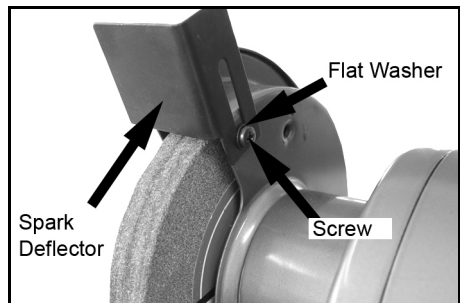

INSTALLING THE EYE SHIELDS

1. Attach the left eye shield arm to the bench grinder using the bracket, flat washer and bolt supplied.

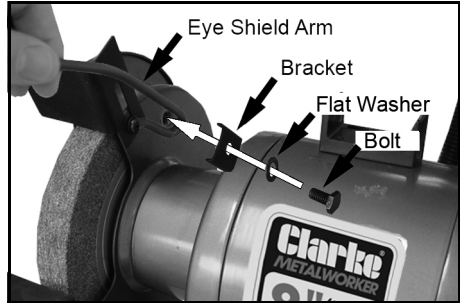

2. Fit the lens to the lens holder as shown.

NOTE: One of the lenses has a magnifying window this should be positioned over the grinding wheel.

3. Repeat for right side eye shield.

- Adjust the eye shields to an appropriate distance from the tool rests avoiding interference during operation.

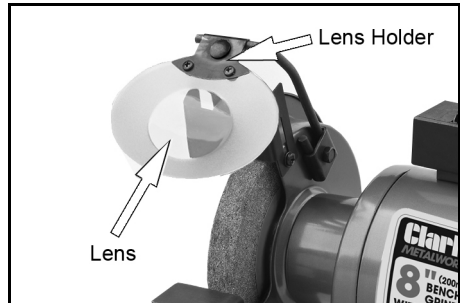

OPERATION



CAUTION: KEEP ALL BYSTANDERS A SAFE DISTANCE AWAY FROM THE TOOL AND NOT IN DIRECT LINE, FRONT OR BACK OF THE GRINDER.

CAUTION: ALWAYS WEAR SAFETY GLASSES

NOTE: Check that there is a 1.5 mm clearance between the tool rest and the surface of the grinding wheel. Adjust as necessary.

NOTE: Check the gap between the spark deflector and the surface of the grinding wheel. This should also be a maximum of 2 mm. Adjust as necessary.

NOTE: Check that the eyeshields have been secured in the correct position and that the grinding wheel lock nuts are tight.

1. Stand to the side of the bench grinder and switch it on using the on/off switch.
 - Let the grinding wheel reach full speed before grinding.

- The wheel rotates in the same direction as the arrow stamped in the side of the wheel guard.
2. Hold the work piece firmly against the tool rest. Hold very small pieces with pliers or other suitable clamps.
 3. Feed the work piece smoothly and evenly against the grinding wheel.
 4. Always keep the work piece moving across the face of the wheel. Grinding against the same part of the wheel will cause uneven wear of the wheel face.
 - Grind only on the face of the grinding wheel and never the side of it.
- NOTE:** Prolonged grinding will cause most tools to become hot. Use care when handling hot tools.
5. Switch the bench grinder off using the on/off switch when you have finished.

USING THE BUILT IN LIGHT

The built in light will come on automatically whenever the bench grinder is switched on.

The arm can bend to set the light in a suitable position.

SHARPENING TIPS

SCISSORS

If possible, take the scissors apart to make the sharpening operation easier and safer. Remove material only from the outside surface and work from the handle end of the blade towards the tip.

KNIVES

Remove metal equally from both faces, working from the handle end of the blade towards the tip.

MAINTENANCE



WARNING: DISCONNECT THE GRINDER FROM THE MAINS SUPPLY BEFORE FITTING REPLACEMENT WHEELS, CLEANING OR ADJUSTMENT.

Keep the machine clean by wiping off dust with a clean cloth, and occasionally blowing the grinder through with compressed air. Always wear protective goggles when blowing through with compressed air.

The grinding wheel may need truing or dressing occasionally. Only dress the wheel with a proper dressing tool whilst wearing safety goggles or glasses. If in doubt seek expert advice.

DRESSING THE WHEEL

When the abrasive wheel starts to become clogged with debris, use the dresser tool supplied to clean (dress) it.

1. Start the bench grinder running.
2. Place the dresser tool on the tool rest with the dresser wheels facing the grinding wheel.
3. Slide the dresser tool forward until contact is made with the abrasive wheel and maintain a light pressure to clean the debris from the abrasive wheel.
4. After dressing, adjust the tool rest and spark deflector as necessary.

REPLACING THE WHEELS



WARNING: DO NOT USE DAMAGED WHEELS.

WARNING: SWITCH THE GRINDER OFF AND DISCONNECT THE POWER SUPPLY BEFORE CHANGING THE WHEELS

1. Loosen the screws shown and rotate and remove the wheel cover.
2. Hold the opposite wheel by hand, and remove the nut and outer flange.

NOTE: The left hand grinding wheel locking nut has a left handed thread.

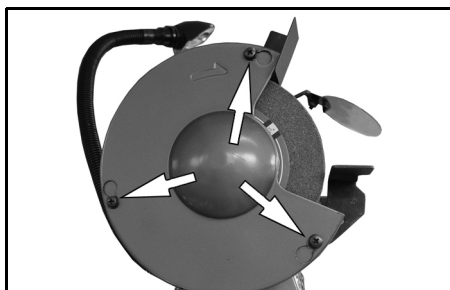

3. Slide off the old wheel and replace with a new one.

- Use only wheels recommended by the manufacturer which have a marked speed equal to or greater than the speed marked on the nameplate of the bench grinder.
 - The disc should have maximum dimensions of 200 mm diameter, 20 mm thick with a bore size of 15.88 mm.
 - Inspect grinding wheel for cracks, chips or any other damage, damaged abrasive products must be destroyed and discarded.
4. Replace the outer flange.
 - Make sure both wheel flanges are placed with the concave sides towards the wheel.
 5. Replace the nut securely.
 - Do not overtighten as this may damage the grinding wheel.
 6. Re-assemble the guards fully prior to carrying out testing.
 - Each time after mounting, the wheel should be test run for a reasonable time (approximately 1 minute).

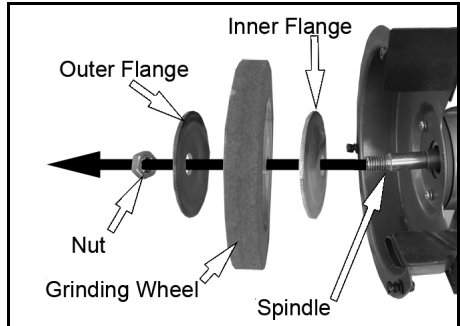

CHANGING THE LIGHT BULB

1. Remove the bulb by twisting it anticlockwise.
2. Replace with an identical bulb (12V, 10W, ES10 fitting) available from the Clarke Parts Department.

ENVIRONMENTAL RECYCLING POLICY



By purchasing this product, the customer is taking on the obligation to deal with its safe disposal in accordance with the Waste Electrical and Electronic Equipment Regulations WEEE.

■ In effect, this means that this product must not be disposed of with general household waste. It must be disposed of according to the laws governing Waste Electrical and Electronic Equipment (WEEE) at a recognised disposal facility.

PARTS DIAGRAM

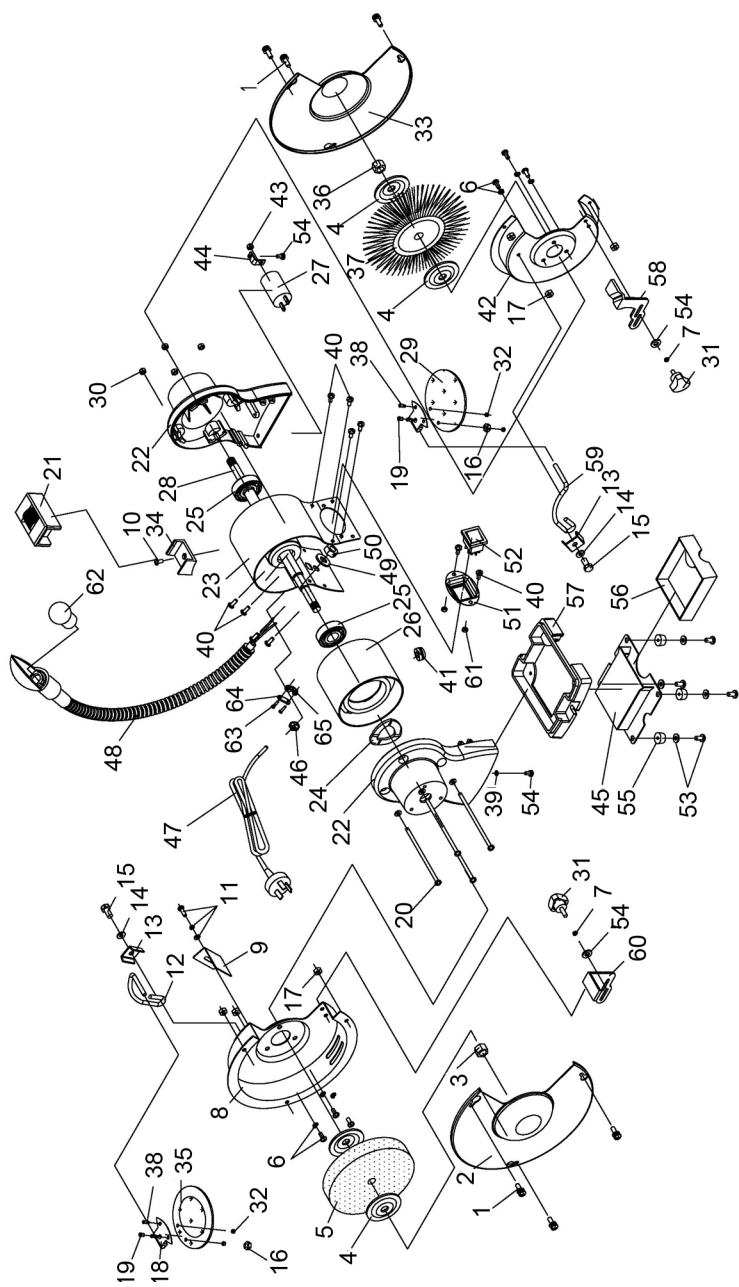

PARTS LIST

1	Phillips Screw
2	Left Guard Cover
3	I type Hex Nut
4	Wheel Flange
5	Wheel (36#)
6	Phillips Screw
7	Standard Washer 5
8	Left Guard inner cover
9	Left Spark Deflector
10	Phillips Screw
11	Phillips Screw
12	Left Eyeshield mounting rod
13	Bracket
14	Flat Washer
15	Hex Bolt M6 x 14
16	Hex Nut M6
17	Locknut
18	Eyeshield press plate
19	Dome Screw
20	Phillips Screw
21	Dressing tool
22	End cap
23	Motor housing
24	Wavy washer
25	Ball bearing
26	Stator
27	Capacitor 6uF/450V
28	Rotor
29	Eyeshield
30	Hex nut
31	Work Rest Lock knob
32	Hex Nut
33	Right guard cover
34	Dresser tool base

35	Magnifying eyeshield
36	Nut
37	Wire wheel
38	Phillips Screw M4x10
39	Toothed Lock Washer
40	Phillips Screw
41	Cable bush
42	Right Guard Inner Cover
43	I type Hex Nut
44	Capacitor Stand
45	Base Plate
46	Cable bush
47	Cable & Plug
48	Lamp Assembly
49	Standard Washer
50	Nut M10
51	Switch Plate
52	Switch
53	Phillips Screw M5x45
54	Phillips screw assy M4x8
55	Rubber foot
56	Water tray
57	Base
58	Right work rest
59	Right Eyeshield mounting rod
60	Left work rest
61	Hex nut
62	Bulb 12V/10W
63	Phillips Screw
64	Wire pressing base plate
65	Wire pressing board

DECLARATION OF CONFORMITY



Clarke[®]
INTERNATIONAL

Hemnal Street, Epping, Essex CM16 4LG

DECLARATION OF CONFORMITY

This is an important document and should be retained.

We hereby declare that this product(s) complies with the following directive(s):

2014/30/EU *Electromagnetic Compatibility Directive.*
2006/42/EC *Machinery Directive.*
2011/65/EU *Restriction of Hazardous Substances, (amended by 2015/863).*

The following standards have been applied to the product(s):

*EN 62841-3-4:2016+A11:2017, EN 62841-1:2015, EN 55014-1:2017, EN 55014-2:2015,
EN 61000-3-2:2014, EN 61000-3-3:2013.*

The technical documentation required to demonstrate that the product(s) meet(s) the requirement(s) of the aforementioned directive(s) has been compiled and is available for inspection by the relevant enforcement authorities.

The CE mark was first applied in: 2011

Product Description: 8" Bench Grinder with Light and 8" Bench Grinder with Light and Wire Wheel.
Model number(s): CBG8370L, CBG8370LW.
Serial / batch Number: N/A
Date of Issue: 15/07/2020

Signed:

J.A. Clarke
Director

A SELECTION FROM THE VAST RANGE OF

Clarke®

QUALITY PRODUCTS



AIR COMPRESSORS

From DIY to industrial, Plus air tools, spray guns and accessories.

GENERATORS

Prime duty or emergency standby for business, home and leisure.

POWER WASHERS

Hot and cold, electric and engine driven - we have what you need

WELDERS

Mig, Arc, Tig and Spot. From DIY to auto/industrial.

METALWORKING

Drills, grinders and saws for DIY and professional use.

WOODWORKING

Saws, sanders, lathes, mortisers and dust extraction.

HYDRAULICS

Cranes, body repair kits, transmission jacks for all types of workshop use.

WATER PUMPS

Submersible, electric and engine driven for DIY, agriculture and industry.

POWER TOOLS

Angle grinders, cordless drill sets, saws and sanders.

STARTERS/CHARGERS

All sizes for car and commercial use.



PARTS & SERVICE: 0208 988 7400

Parts Enquiries
Parts@clarkeinternational.com

Servicing & Technical Enquiries
Service@clarkeinternational.com

SALES: UK 01992 565333 or Export 00 44 (0)1992 565335

Clarke INTERNATIONAL Hemnall Street, Epping, Essex CM16 4LG
www.clarkeinternational.com